



PROFESSIONAL DEEP CYCLE AGM

Key benefits

- Ideal for high-performance electric boats, yachts, motorhomes
- AGM technology for high rate discharge performance, plus superb shock and vibration resistance
- Exceptionally long lasting – up to eight times the cyclic stability of conventional batteries
- Tough, leak proof construction
- Ideal for all your starter and supply requirements

For more information visit www.varta-automotive.com

ORDER INFORMATION

European Type No. (ETN):	830 260 120
Article Number:	830 260 120 D95 2
Short Code:	LAD 260
Barcode:	4016987143643
Packaging Unit:	1
Quantity per Pallet:	12

TECHNICAL INFORMATION

Voltage [V]:	12	Width [mm]:	269
Battery Capacity [Ah]:	260	Height [mm]:	239,5
Battery Capacity 5h [Ah]:	214	Base Hold-down:	B00
Cold Cranking Amps (CCA), EN [A]:	1100	Layout:	3
Cold Cranking Amps (SAE) @ -18°C:	1200	Terminal Types:	1
Marine Cranking Amps (SAE) @ 0°C:	1440	Weight filled (kg):	77,9
Length [mm]:	521		

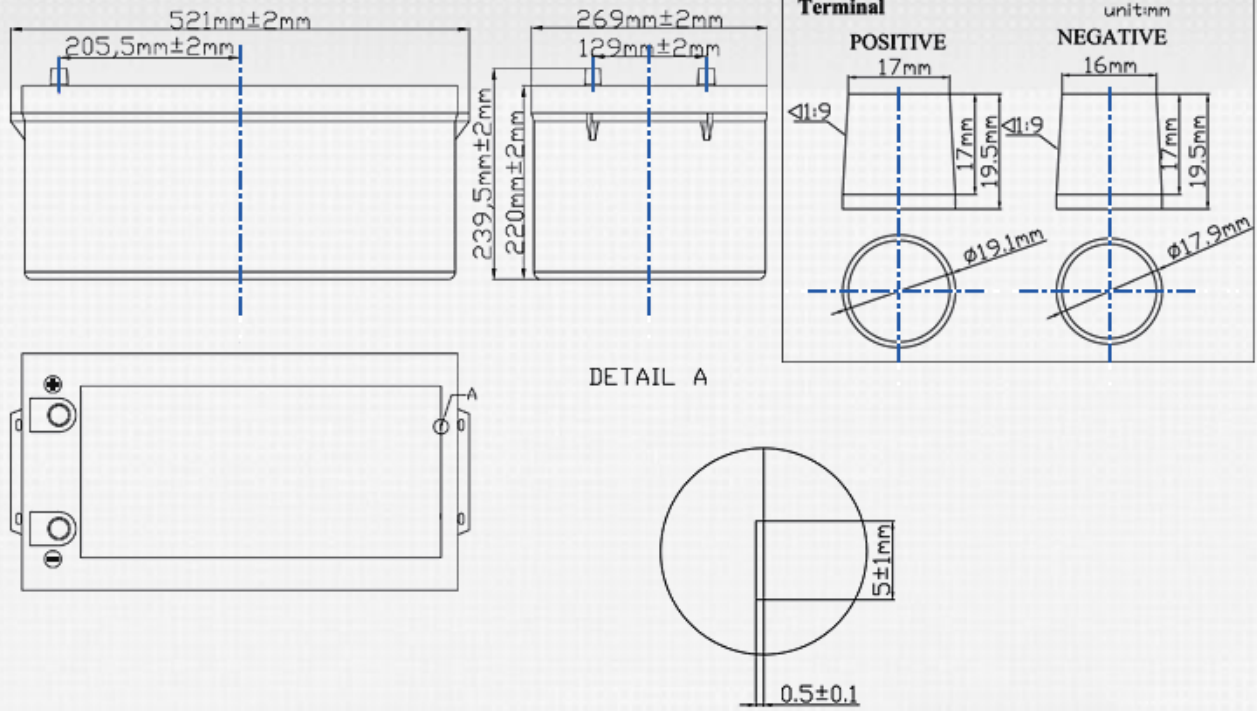

Discharge Curves

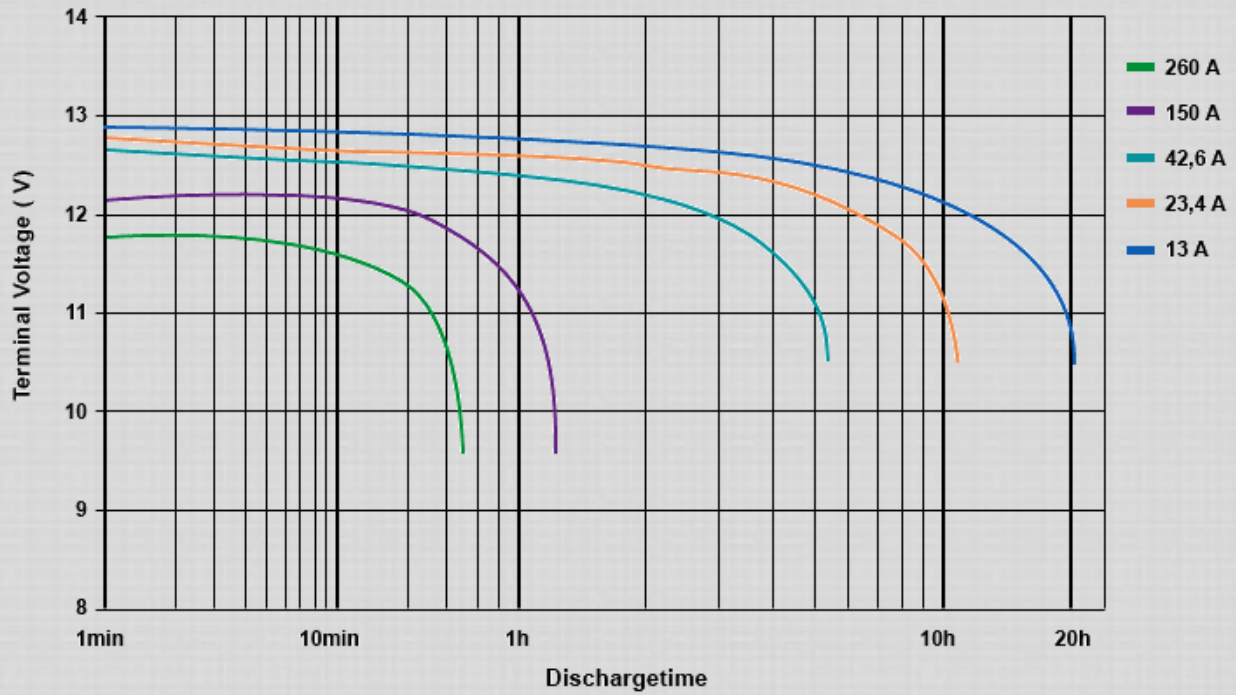

Individual results may vary